

CFB-60

CARTRIDGE STYLE FLOW RESTRICTOR VALVE

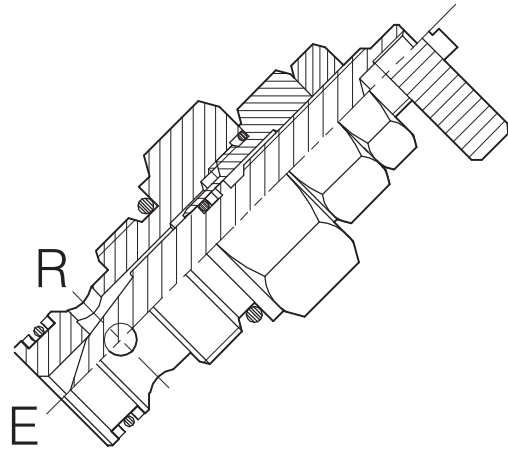
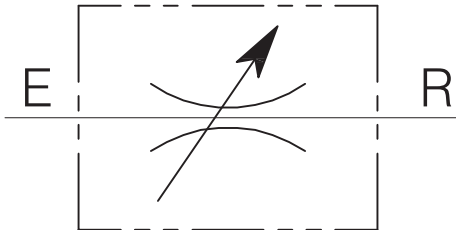

Performance

Rated size	DN 8
Min/Max flow-rate	1/60 l/min - 0.26/15.9 GPM
Max working pressure	245 bar - 3550 PSI
Room temperature	-30°C + 50°C
Oil temperature	-30°C + 80°C
Recommended filtration	50 micron
Tightening torque	50 ÷ 60 Nm
Weight	0.153 Kg

Performance Details

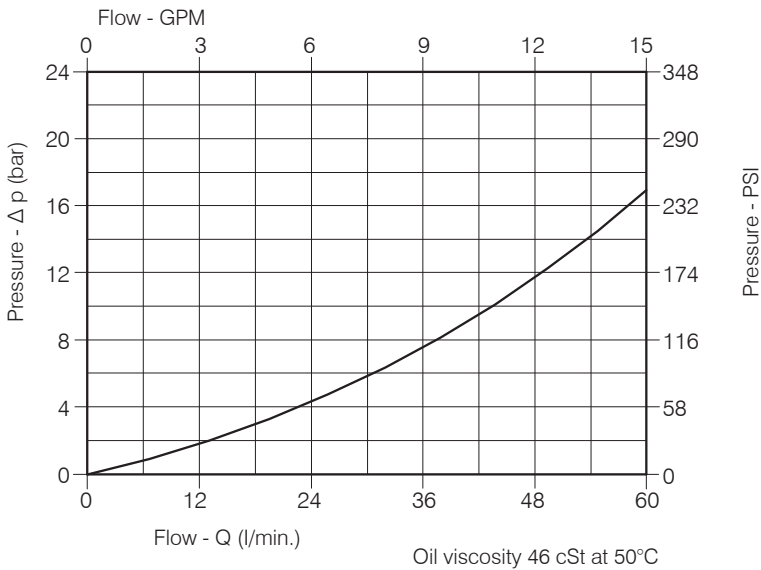

CFB-60

Hydraulic valves and integrated components

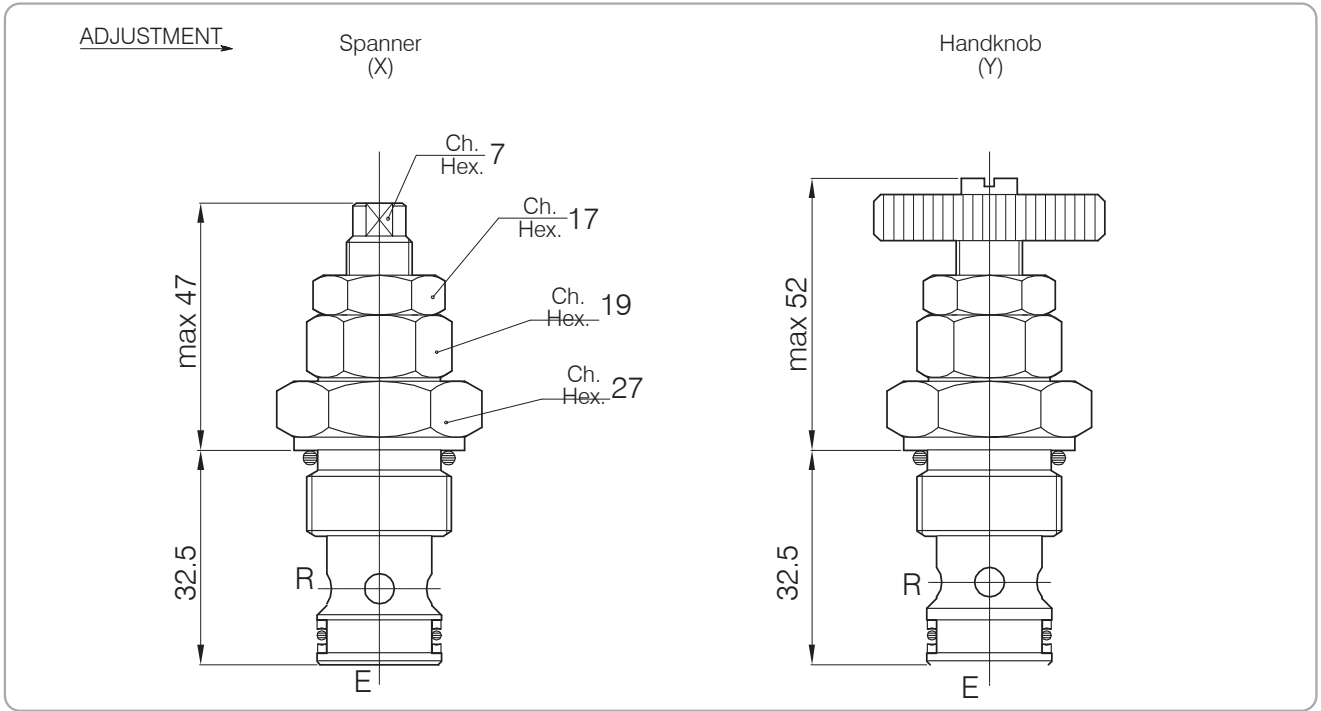

Cavity CE.014.N

Typical Circuit Example

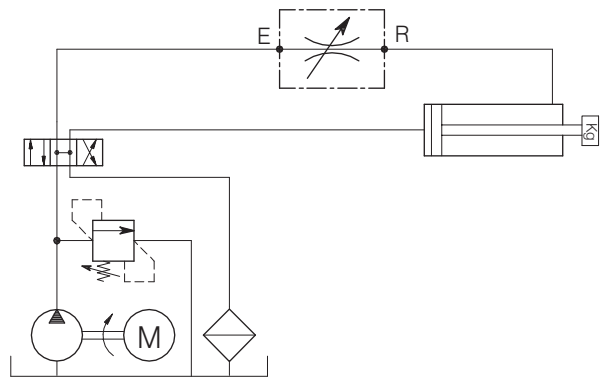
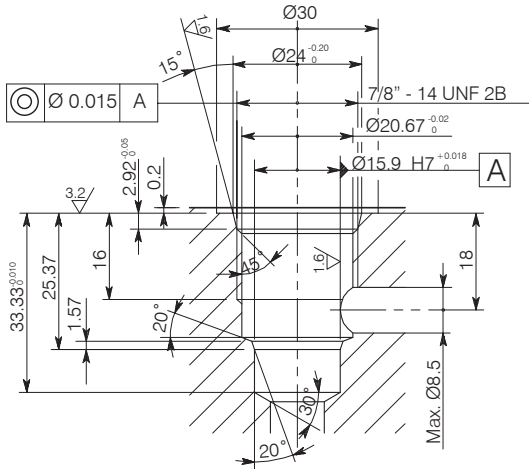

The valve seat should be perfectly tooled

Ordering Code



Cracking pressure
 X : Spanner
 Y : Handknob